

INSTRUCTION MANUAL  
**Scotch – Yoke**  
**Part turn pneumatic actuator**  
GD08

CONTENTS

1) GENERAL FEATURES.....	pg.2
2) WORKING CONDITIONS.....	pg.2
3) OPERATION AND ROTATION DIRECTION.....	pg.4
4) SAFETY NOTICE.....	pg.5
5) INSTALLATION INSTRUCTION.....	pg.6
6) MAINTENANCE AND MATERIALS SPECIFICATION .....	pg.7
7) ATEX 94/9/EC.....	pg.12
8) STORAGE.....	pg.12
9) TROUBLESHOOTING GUIDE .....	pg.12
10) DISPOSAL .....	pg.13

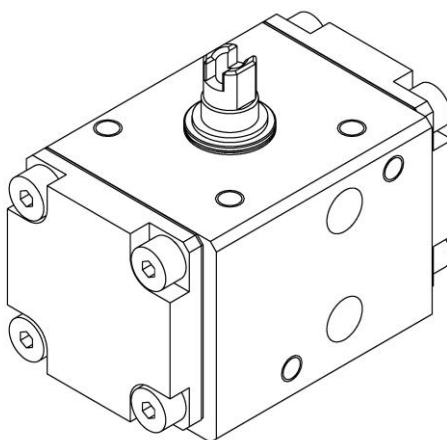

Actuatech will be free to change all the specifications and data included in this manual at any time , so as to improve the quality and the performance of its products.

## 1) General features

The GD08 is a part turn pneumatic actuators for valve remote control.  
This actuator is available only on Double Acting "GD" version.

- The principle of the actuator application is to open and close the connected valve, without the manual operation with lever or hand wheel, by means of an electric-pneumatic connection on remote control.

- Scotch – Yoke is a mechanical system that allows to transform the linear force into a rotary torque.  
Actuatech applies the scotch - yoke system for its actuator production to transfer the pistons linear force to a driving shaft torque.  
This system provides a long working life and best performance with the minimum energy consumption.

-The maintenance should be done by Actuatech trained personnel only.

This instruction manual contains important information regarding the Actuatech Scotch-Yoke pneumatic actuator operation, installation, maintenance and storage.

Please read carefully before installation and keep it in a safe place for further reference.

## 2) Working conditions

### a) Construction.

Standard Actuatech actuators are suitable for indoor and outdoor installation. The laser marking or a printed label on the actuator body gives the actuator technical characteristics: type, size, operating pressure, output torque, operating temperature, flange connection, product code and production date . ( see drawing pag.3 ).

### b) Motive energy

The operating media should be dry and filtered compressed air not necessarily lubricated or inert gases compatible with internal actuator parts and lubricants.

The operating medium shall have a dew point equal to – 20 °C or, to be at least, 10 °C below the ambient temperature ( ISO 8573-1, Class 3 ). The maximum particle size shall not exceed 40 µm ( ISO 8573-1, Class 5 ).

### c) Supply operating media pressure.

The maximum supply pressure is 8,4 bar ( 120 psi )

Nominal supply pressure is 5,6 bar ( 80 psi ), working pressure range from 2,5 bar ( 36 psi ) up to 8,4 bar (120 psi ).

### d) Operating temperature.

Actuator standard working temperature range form –20°C ( -4°F ) to 80°C ( 176°F )

For low and high temperature versions please contact Actuatech.

### e) Operating drive rotation.

The part turn actuator rotation angle is nominally 90°. Actuatech actuator provides a stroke of 92°.

### f) Cycle time.

The cycle time is dependent on different operating and installation factors such as the supply pressure, the flow capacity, the connection pipe size, the solenoid valve performance, the valve torque and characteristics, environmental temperature condition.

Actuator opening , closing and open/close cycle times ( sec. ).

Actuator size	0°-90° cycle time	90°-0° cycle time		Actuator size	0°-90° cycle time	90°-0° cycle time
	SEC	SEC			SEC	SEC
<b>GD08</b>	0,03	0,03		-	-	-

The above time table is referred to a standard actuator working cycle at the following tests conditions :

Ambient temperature: 18°C – 25°C  
Motive energy operating medium: compressed air at 5,6 bar  
Nominal cycle: 90° in both directions  
Load: free  
GD actuators operate with solenoid valve 5/2 ISO 1-2.  
Time tested with Electronic Timer device.

NOTE: different working condition such as air pressure, piping connection, filters or solenoid valves, could change the timing of the operations.

### g) Lubrication.

The actuators are factory lubricated for the standard working condition life.  
During maintenance and reassembling Actuatch recommends to use TECNOLUBE SYNTHY POLYMER 402, or equivalents.

### h) Internal wear protection

The cylinder is lapped to obtain a surface with fine roughness and is protected with 20 µm technical oxidation. The pistons slide supports are in P.T.F.E. . The use of steel bearings on the Scotch-Yoke system ensures no play and low friction during operation

### i) External protection

Actuatech standard actuators are suitable for indoor and outdoor installation. The aluminium body is external protected from corrosion and wear with 20 µm technical oxidation. The cast aluminium end caps are polyester painted. Driving shaft and caps screws are in alloy steel nickel plated.

For aggressive atmosphere and severe environmental condition select the required protection from the external finishes showed in our catalogue or contact directly our technical department.

### l) Marking and classification

All Actuatch actuators bodies are marked with the Manufacturer name and address, the actuator Type code including the Series and Size, and its range of Pressure and Temperatures working conditions and limits.

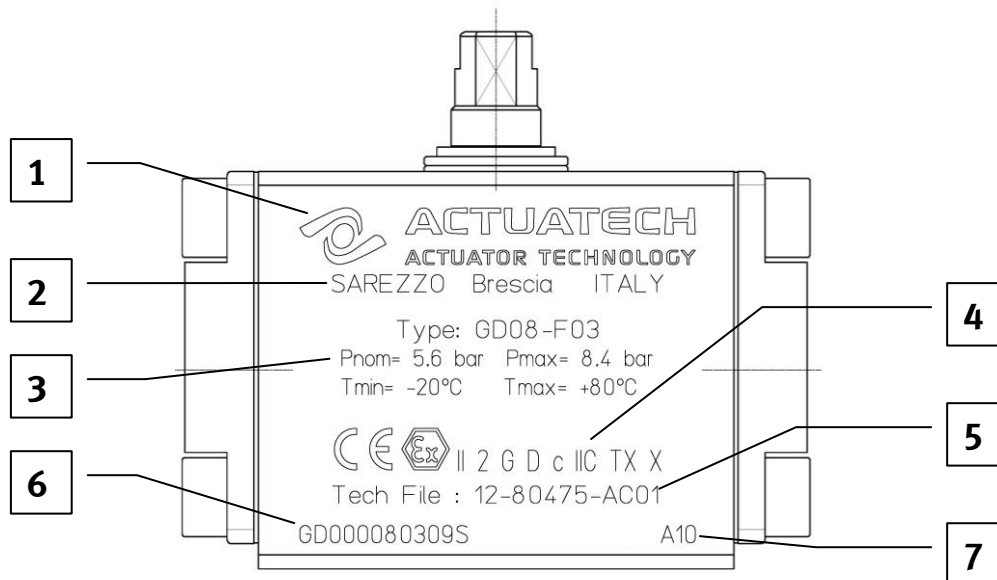

1. Name of the company in charge of marketing the product in the E.U.
2. Address of the company in charge of marketing the product in the E.U.
3. Model, operating pressure and temperature.
4. Class of compliance with the rules and level of protection "c", gas group IIB or IIC, temperature class TX.
5. Name of Technical File deposited with a Notified Body.
6. Product code.
7. Month and year of production.

### 3) Operation and rotation direction

#### Double Acting.

The pistons of standard GD actuators are mounted as shown below. This provides the highest torque at the valve start opening for valve clockwise to close.

The port 2 is in connection with the cylinder side chambers, supplying the pressurised air in port 2 the standard Double Acting actuator drive shaft rotates counter clockwise to open, while the port 4 is in connection with the intermediate chamber and when pressurised the drive shaft rotates clockwise to close.

#### Double Acting operation cycle

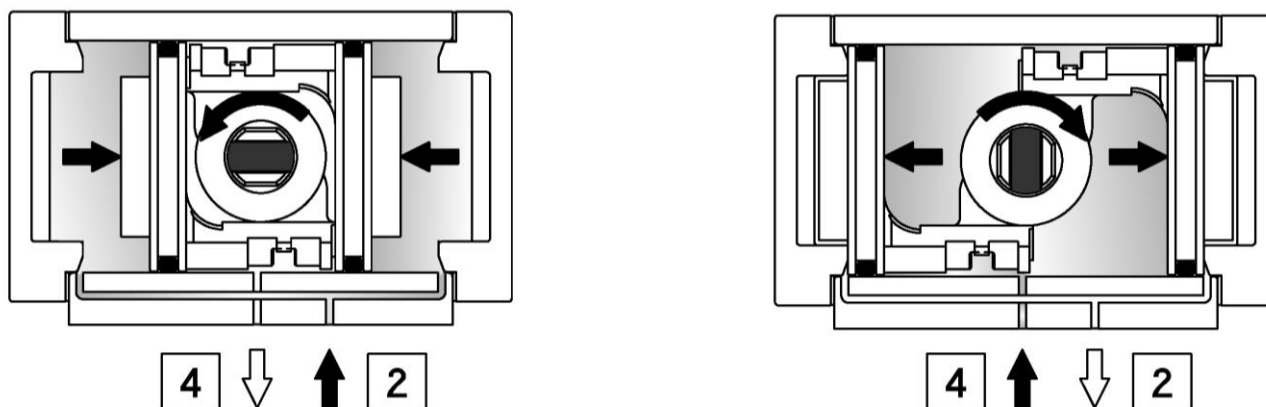

#### Important.

Special version with different piston positions have different rotation to close and to open: please follow their special instructions.

Actuator operation functionality remote control should be done by means of pipes screwed on the ports marked with the numbers 2 and 4 and connected to a separate control cabinet.

Fig 3,1 – Typical air connection schema .

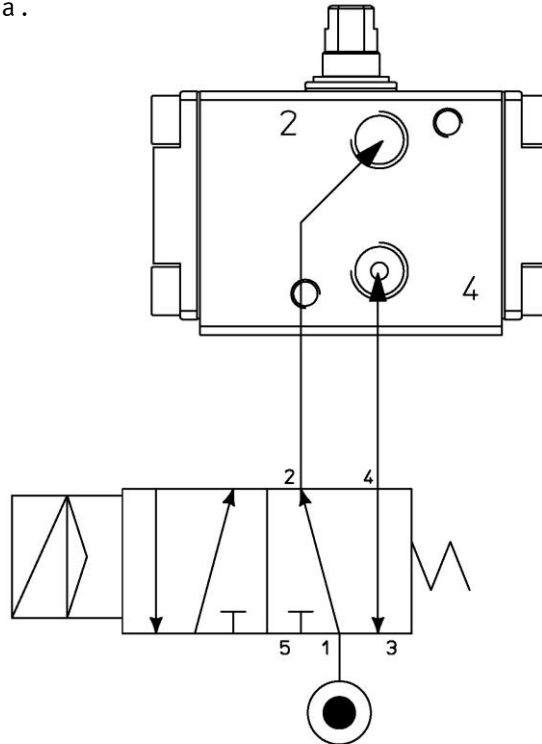

A) Rotation direction.

In accordance with the international standard ISO 5599-2 the actuator air ports connection position, location, orientation and form shall be clearly identified and marked with the numerate 2 and 4.

Standard Double Acting actuators shall be Clockwise ( CW ) direction to valve Close, and Counter Clockwise ( CCW ) direction to valve Open.

**4) Safety notice**

- The actuator should be used within the pressure mentioned limits only, operating the actuator over the pressure limit will damage the internal actuator parts.
- Operating the actuator over or under the temperature limits will damage the internal and external parts.
- Operating the actuator in corrosive environments without the required external protection will damage the actuator.
- Before installation, service or maintenance verify that the actuator is not pressurised, disconnect the air lines and make sure that the air ports are vented
- Do not remove the end caps while the actuator is installed in the line, or while the actuator is under pressure.
- Before mounting the actuator onto the valve make sure that the valve rotation is according with the actuator operating rotation, and the upper shaft slot orientation is also correct.
- Before installing the actuated valve do cycling test for a while to ensure the correct mechanical mounting and actuator/valve operations.
- The actuator installation shall be done according to and in observance with the local and national laws regulation.
- **Actuatech Srl can not be responsible for any damage to people, animals or things due to an improper use of the product.**

## 5) Installation instruction.

.....

The principle of the actuator application is to open and close the connected part turn valve installed in a plant, without the manual operation, by remote control by means of an electric-pneumatic connection.

The normal sizing of actuators require a 20%-30% safety margin over the valve breakaway torque to handle valves. Plant design, chemical and physical flow characteristics and environmental condition could increase the safety factor to apply to actuator sizing. Before performing any installation operation, verify the actuator and valve conditions according to the safety notice above described.

Moreover the utmost clearness is required during valve installation of the air supply connection to the actuator. All the connection parts such as reductions, joints, plates, brackets and equipment must be clean and dirty free.

Before assembling the actuator onto the valve make sure that both items are correctly oriented, depending upon which direction of rotation is required.

- Before starting the actuator installation, should be done a visual actuator control to verify its physical condition after transportation and storage.
- Control trough the shaft slot or caps the actuator position
- Read carefully the Actuatch instruction sheet included in the cardboard box
- Read the actuator limits and performances marked on the actuator body to verify its suitability
- Remove the protection label stickers from the ports
- Before fitting the actuator on the valve, clean the valve and the actuator from the dust and dirt.
- Verify the valve position, close or open, and the rotation direction.

### Valve/Actuator assembly:

#### A) Direct mounting.

Valve actuator Direct mounting is the best solution to avoid plays between valve stem and actuator drive shaft. For a direct mounting you should have the same standard flange connection on valve and actuator as well as the valve stem dimensions that fit perfectly with the actuator drive. Before installation please verify that the actuator and valve flange ISO connections are the same size; verify that the valve stem size and shape is suitable for direct mounting, if necessary use a drive reduction.

Fit the valve stem into the actuator drive shaft connection, and bolt together the two ISO flanges.

#### B) Mounting plate connection.

In case direct mounting is not possible cause of little differences in actuator/valve flanges or drives sizes, mounting plates adapters with suitable flanges dimensions allows an easy connection living a sufficient space for the valve/actuator drive adapter.

#### C) Bracket & Joint connection.

Wherever for technical reason the plant installation requires a distance between actuator and valve, or the valve flange and/or stem are not standard, and in any case, where the valve/actuator connection could not be possible, a bracket and joint is the right answer. The Bracket is a steel bridge that allows to connect the valve with its own flange connection in one side and with the suitable actuator connection onto the opposite side, living a space in between for a steel joint connection. The joint allows a drive connection between the actuator and the valve stem indispensable in case of stem key drive and flat head.

Chose the suitable flange bracket and the required joint connections to fix the actuator onto the valve very tight without any plays.

## Screw torque wrench setting

SIZE	TORQUE Nm
M5	5-6

## 6) Maintenance and materials specification

.....

Life time 20 years or number of cycles as per EN15714-3 2009 ( see table below ).

Nominal torque <sup>a</sup> Nm	Piston or vane actuator Minimum number of cycles <sup>b</sup>	Maximum stroking time for testing, based on 0-90° s
≤125	500 000 <sup>c</sup>	3
≤1 000	500 000	5
≤2 000	250 000	8
≤8 000	100 000	15
≤32 000	25 000	20
≤63 000	10 000	30
≤125 000	5 000	45
≤250 000	2 500	60

<sup>a</sup> Based on EN ISO 5211.  
<sup>b</sup> One cycle consists of nominal 90° angular travel in both directions (i.e. 90° to open + 90° to close). For angular travel other than 90°, the endurance shall be agreed between the purchaser and the manufacturer/supplier.  
<sup>c</sup> For thermoplastic actuators the minimum number of cycles shall be 250 000.

Should it be necessary to replace its pistons sealing, this operations must be done by Actuatech trained people with proper tools, we recommend to return the actuator to Actuatech where the actuator will be overhauled and than tested for a correct replacement. On request Actuatech will be willing to provide its sealing Kits.

**!!! Actuatech declines any responsibility for the products repaired by third parties**

Fig 6,1 Actuator components and material list.

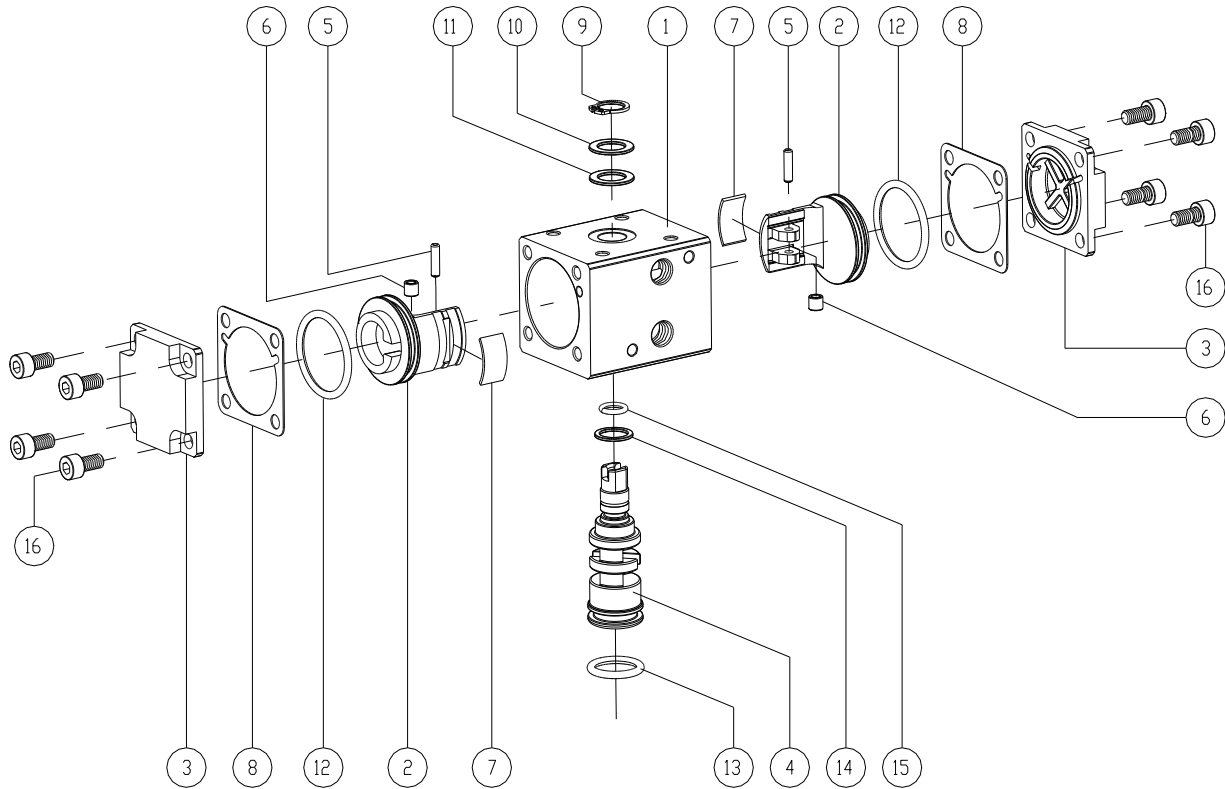

POS.	DENOMINATION	Q.	MATERIALS	STANDARDS
1	Cylinder	1	Aluminium alloy	Anodized
2	Piston	2	Aluminium alloy	Nickel plated
3	Cap	2	Aluminium alloy	Painted
4	Shaft	1	Steel alloy	Nickel plated
5	Sleeve	2	Steel alloy	DIN 6325
6	Bush	2	Steel alloy	Hardening
7*	Support band	2	Acetalic resin	
8*	Cap seal	2	Nitrilic rubber	
9	Seeger	1	Stainless steel	UNI 3653 - DIN 471
10	Washer	1	Stainless steel	UNI 3653 - DIN 471
11*	External support ring	1	Acetalic resin	
12*	O-ring	2	Nitrilic rubber	
13*	O-ring	1	FKM	
14*	Internal support ring	1	Acetalic resin	
15*	O-ring	1	FKM	
16	Screws	8	Stainless steel	AISI 304 – DIN 1.4301

\* Parts included in the spare parts kit.

Fig 6,2 Spare parts kit code identification for actuator size.

TYPE	KIT CODE
GD08	KGGIO010



### Disassembly.

Actuator disassembly operation must be done with the actuator free from any pneumatic and electric connection and dismantled from the valve.

Verify that the actuator is air bag free.

Check that the air port 2 and 4 are absolutely vented.

Use proper tools only.

- A) Loosen the end cap screws (part N° 16) in cross sequence to remove the end caps (part n° 3). The end caps contain a seal (part N° 8) on its seat that should be checked before replacement.

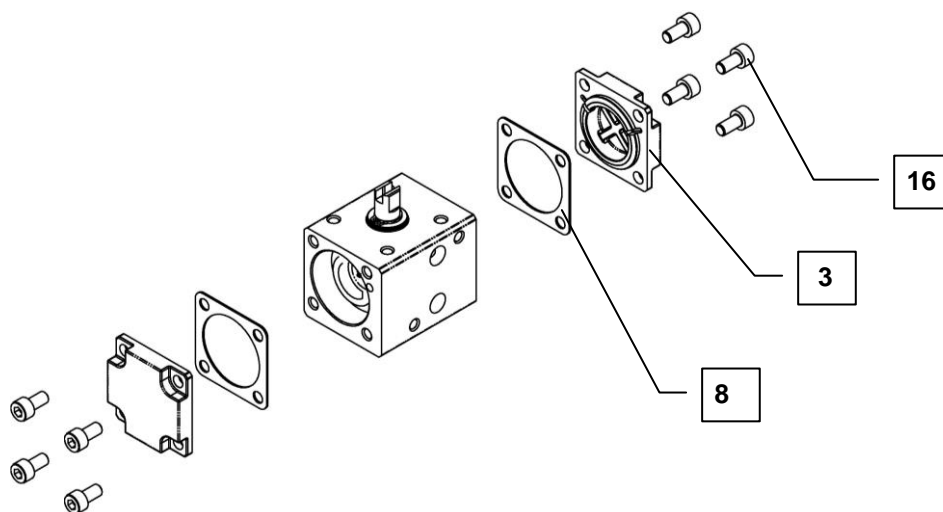

- B) Hold the actuator in the vice and rotate the drive shaft until the pistons (part N° 2) are released from the scotch-yoke grooves (part N° 4), then slip off the pistons from the cylinder (part N° 1). Do not use compressed air to remove the pistons from the body, this operation could cause personal injuries.

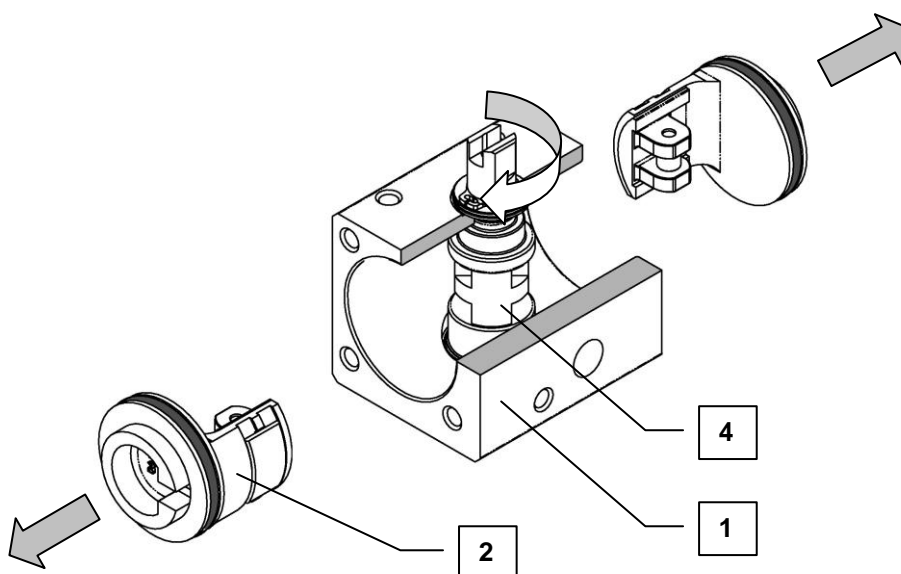

- C) The pistons O-ring ( part N° 12 ) and supports ( part N° 7 ) should be checked before replacement. Do not use sharp tools to remove O-ring or the supports from the piston as this may cause furrows or marks.

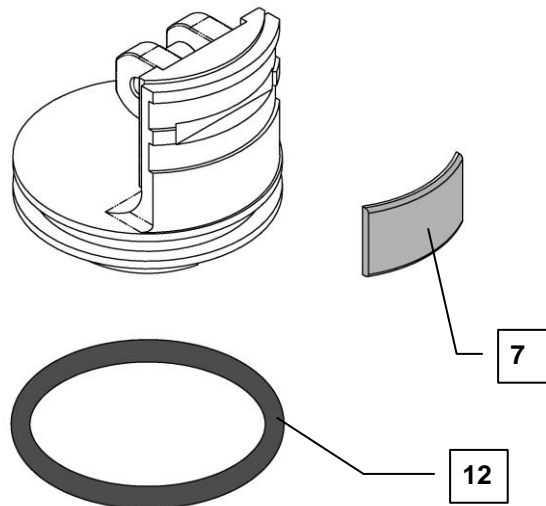

- D) When the components are disassembled, they should be properly cleaned and wear checked prior to being greased and reassembled. In case the sealing parts are too much worn out use new parts from the spare parts kit.

### Assembly.

- A) O-ring ( part N° 12 ) shall be greased and mounted onto the piston seat using a proper conical tool that allows an easy and perfect slip-in of the items without any damages.
  - B) Push into its piston seats the P.T.F.E. supports ( part N° 7 ).
  - C) Grease the pistons ( part N° 2 ) on the replaced parts ( parts N° 7+12 ).
  - D) Grease the internal cylinder surface ( part N° 1 ).
  - E) Position the scotch-yoke shaft ( part N° 4 ) in order to have the grooves in position for the pistons insertion ( see Fig. B ) and the right shaft required direction of rotation.
  - F) Insert the pistons ( part N° 2 ) in the scotch-yoke grooves ( part N° 4 ) and press simultaneously the two pistons inside of the cylinder ( part N° 1 ). The Actuotech scotch-yoke system will avoid pistons misalignment. Holding the actuator on a vice rotate the shaft to verify the shaft rotation direction and the easy movement.
  - G) Replace the cap seal ( part N° 8 ) on its caps seat ( part N° 3 ) and grease it. Fit the end caps to the body screwing the screws in cross ( part N° 16 ) .
- N.B. For the screw torque wrench setting see pg 6 .

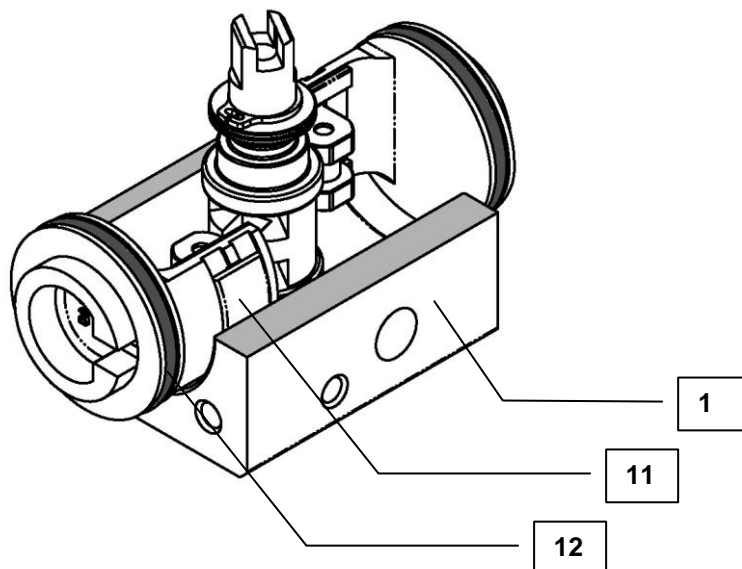

Fig. A

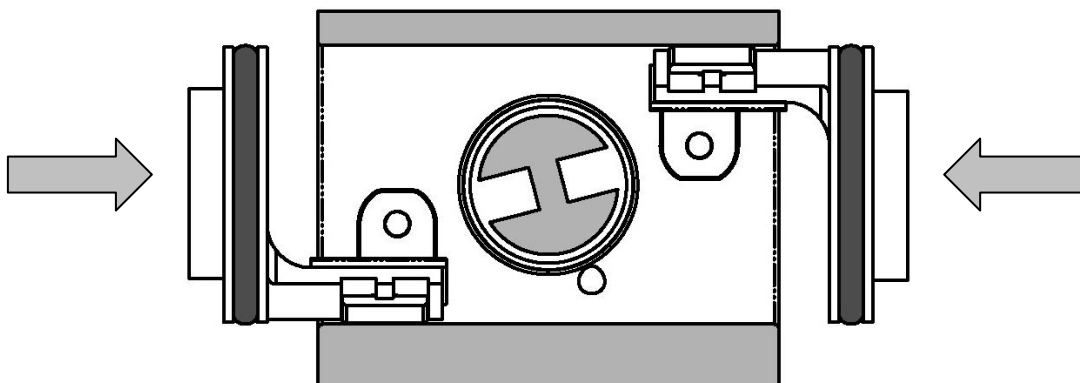

Fig. B

## 7) Atex 94/9/EC

In conformance with the European Directive ATEX 94/9/CE for the suitability of the equipment intended for the use in Potentially Explosive Atmosphere, Actuatch declare the conformity of the scotch-yoke actuator of the above mentioned Atex directive in the limits of its Classification and Zone Classification.

Classification:

Product Classification: Equipment Group II Category 2

Zone Classification: Suitable for Gas Zone 1, and Dust Zone 21.

Protection Class : "c" constructional safety

Gas group IIC / IIB

Temperature Class TX, Determined by Environmental Temperature and Operating Media Temperature.

Whenever the actuator may be installed in the Potentially Explosive Atmosphere the operator before start the installation must observe the suitability of the equipment classification and special installation instruction included that follow the actuator. In case of instruction missing or any doubts please call the Actuatch technical department.

### Attention.

Keep the actuator in its original box until the installation, and store it in dry and clean environment at temperatures between -10°C and +60°C .

## 8) Storage

The Actuatch actuator has been packaged to provide protection during shipment, however, it can be damaged in transport. Prior to storage, inspect the actuator for shipping damage. Keep the actuators in their original packing box during storage. It is recommended to keep the actuators in a clean and dry environment at temperatures between -10°C and +60°C until ready for use.

The actuator has two air ports , which are closed by labels for prevent liquids or others material to entering in the actuator during storage.

If the actuators are to be stored for a long period of time before installation, it is recommended to stroke them periodically to prevent setting of the seals.

Store the actuators indoors to protect them from humidity and dust.

## 9) Troubleshooting guide

SYMPTOM	POSSIBLE CAUSE	SOLUTION
Loss or reduction of output torque	No air supply	Connect air supply
	Insufficient air supply to produce required torque	Increase air supply
	Loss of air due to seal leakage	Replace worn seals
Air leak at top or bottom shaft	Damage O-ring seal	Contact Actuatch
	Damage to body bore	Contact Actuatch
	Damage to pinion shaft	Contact Actuatch
Air leak at end cap and body seal	Damage end cap seal	Replace end cap seal
	Dust in the home of cap seal	Clean the cap
Air leaking from either port after operation	Damaged piston seal	Replace piston seal
	Damaged body cylinder	Contact Actuatch
Insufficient valve rotation	Actuator has failed	Repairs or replace
	Insufficient air supply to produce required valve torque	Increase air supply
	Actuator mechanical stop ( if present ) not properly adjusted	Adjust actuator stops allow more travel
	Incorrect fit between actuator output bore and valve stem	Check actuator to valve adapter for proper size and fit

## 10) Disposal

.....

Observe all regulations and laws governing the disposal of hazardous substances to the environment .

For specific guidance on the materials to be disposed see the Actuatech Environmental Policy Document Ref: 81137